

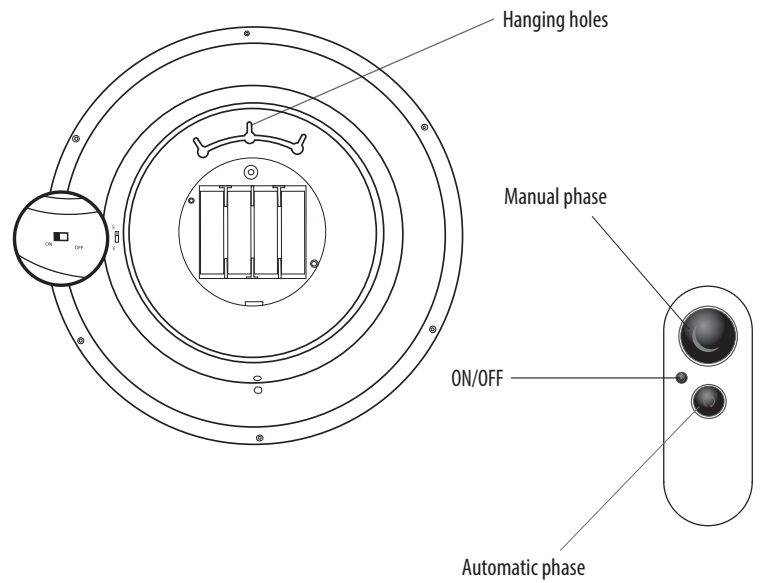

EARTH IN MY ROOM

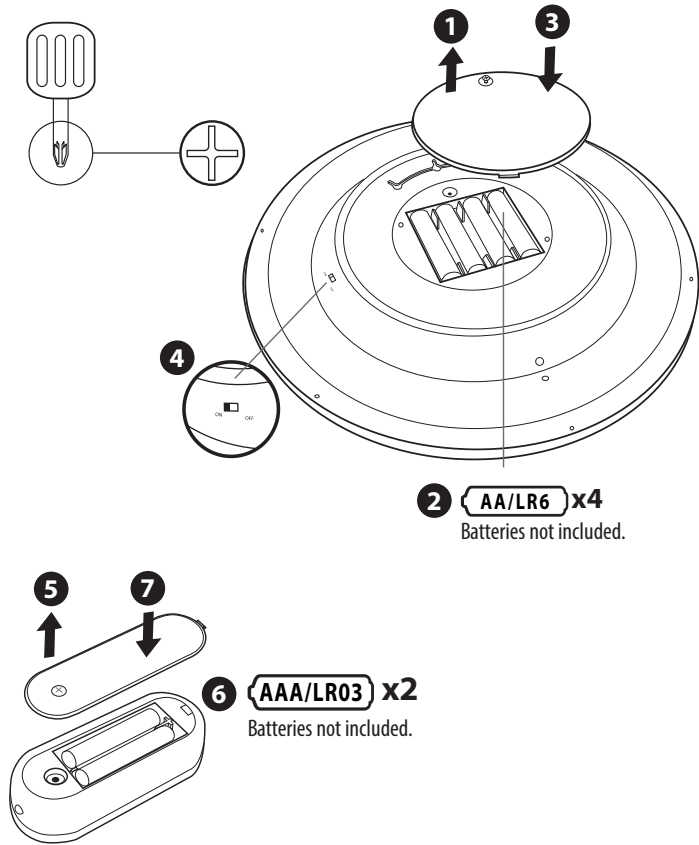

AUTO OFF: Earth automatically shuts off after 30 minutes.
Do not hang the Earth above where a child sleeps.

KEEP THESE INSTRUCTIONS FOR FUTURE REFERENCE — DO NOT DISCARD
Questions? Visit unclemilton.com

BATTERY SAFETY INFORMATION

- Only adults should install and replace batteries.
- Non-rechargeable batteries are not to be recharged.
- Rechargeable batteries are to be removed from the toy before being charged.
- Rechargeable batteries are only to be charged under adult supervision.
- Different types of batteries or new and used batteries are not to be mixed.
- Batteries are to be inserted with the correct polarity.
- Exhausted batteries are to be removed from the toy.
- The supply terminals are not to be short-circuited.
- Do not mix old and new batteries.
- Do not mix alkaline, standard (carbon-zinc) or rechargeable (nickel-cadmium) batteries.
- Do not dispose of batteries in fire. Battery may explode or leak.
- Batteries should be recycled or disposed of as per state and local guidelines.

WARNING! Not suitable for children under 36 months.
Small Parts. Choking hazard

This product and its batteries must be disposed of separately at your local waste recycling center. Do not dispose them in your household waste bin.



NOTE: This equipment has been tested and found to comply with the limits for a Class B digital device, pursuant to Part 15 of the FCC Rules. These limits are designed to provide reasonable protection against harmful interference in a residential installation. This equipment generates, uses and can radiate radio frequency energy and, if not installed and used in accordance with the instructions, may cause harmful interference to radio communications. However, there is no guarantee that interference will not occur in a particular installation. If this equipment does cause harmful interference to radio or television reception, which can be determined by turning the equipment off and on, the user is encouraged to try to correct the interference by one or more of the following measures:

- Reorient or relocate the receiving antenna.
- Increase the separation between the equipment and receiver.
- Connect the equipment into an outlet on a circuit different from that to which the receiver is connected.
- Consult the dealer or an experienced radio/TV technician for help.

This device complies with Part 15 of the FCC Rules.

Operation is subject to the following two conditions:

- (1) This device may not cause harmful interference, and
- (2) This device must accept any interference received, including interference that may cause undesired operation.

Caution: changes or modifications not expressly approved by the party responsible for compliance could void the user's authority to operate the equipment.

In an environment with electrostatic discharge, the product may malfunction.
In this case, remove the batteries and wait for 5 minutes and then replace the batteries.



MANUFACTURED BY UNCLE MILTON
301 YAMATO RD, SUITE 2112; BOCA RATON, FL 33431 USA
© 2017 TBDUM, LLC DBA UNCLE MILTON, all rights reserved.
® and TM designate trademarks of Uncle Milton.
MADE IN CHINA